

Sector Port Entry Light

SL-PEL Series - 5° & 10° Models

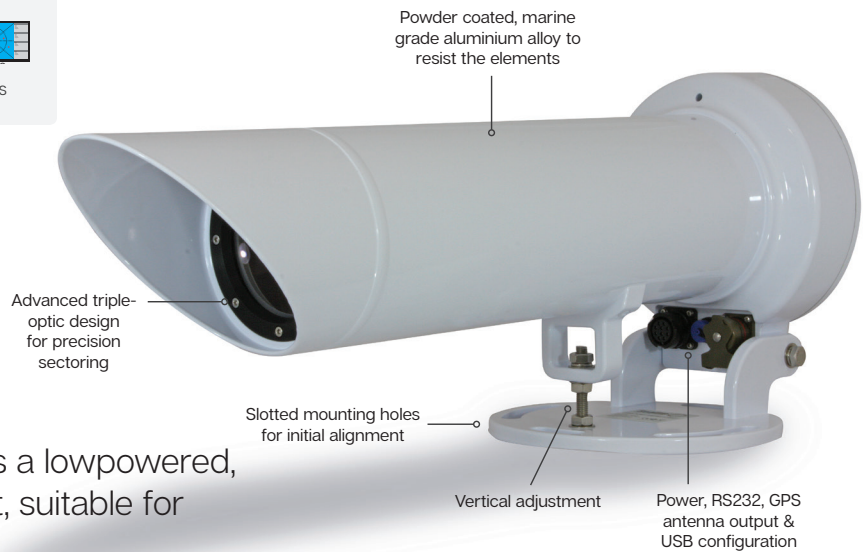
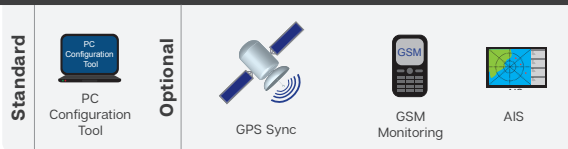

The Sealite Port Entry Light (PEL) is a lowpowered, high-intensity precision sector light, suitable for day or night-time use.

High Precision, Long Range LED Optics

Providing over 120,000cd (10° Model) and over 500,000cd (5° Model) at 30 watts, the Sealite PEL is extraordinarily efficient and ideal for solar power systems. The light is designed to suit high-precision sector applications and provides a measured changeover between colour sectors of typically one minute of arc.

Robust, with Ultra-Low Power Consumption

The Sealite PEL is extremely robust and of high-quality construction. The unit is built from CNC machined marine grade aluminium alloy, subject to 7-stage powder coating. The IP67 rated enclosure with anti-reflection coated achromatic lenses offers maximum resistance to weather.

AIS & GSM Ready

The Sealite PEL comes ready for interfacing with Sealite Type 1 or Type 3 AIS solutions, to allow port operators convenient remote monitoring of the unit via AIS message 6. In addition, important AIS message 21 information such as the name, type, and position of the navigation aid may be broadcast to mariners within the region.

GSM monitoring facilities also allow the light to be remotely monitored and controlled by maintenance personnel through their cellular phones or web portal.

Sealite's PEL also has alarm relay contacts for remote monitoring to alert to fault conditions.



Anti-reflection coated achromatic lens to give maximum resistance to weather



Power, RS232, GPS antenna output and USB configuration

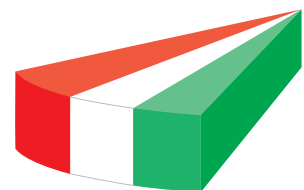

High-precision light sectoring



The Sealite Advantage

- Low power consumption – typically uses 30 watts to achieve intensities that previously required 250 watts, making solar power possible
- LEDs can be configured for automatic night dimming, eliminating the need for moving filter
- LEDs can be individually flashed, reducing the need to employ moving oscillating boundaries
- AIS & GSM ready – comes ready for interfacing with AIS or GSM monitoring facilities
- Lightweight for ease of installation
- At only 30 watts, the PEL can be run on a 12-24 volt DC supply without the need for large cables
- Ultra compact design - removing the need for split assemblies and realignment on difficult access sites
- GPS options enables reliable synchronisation with multiple units and other AtoNs
- Independent verification of conformity to IALA colour chromaticity co-ordinates and angles of uncertainties
- Optional solar powered configurations available



SL-PEL-5 Model

GPS Synchronisation

The Sealite PEL may be fitted with GPS, to enable reliable synchronisation when multiple units or Sealite GPS enabled lanterns are set to the same flash character. Furthermore, offset synchronisation can be achieved using multiple units with the same divisible total flash period, for better recognition.

Convenient PC Programming via USB

Up to 32 sector intensity steps may be selected by the user during programming to enable in-field adjustment to offset local background lighting. Over 256 standard & custom flash codes can also be programmed, in addition to advanced features such as multiple day/night intensity settings & switching between internal and external photo-cells. In-field programming is via a built in weather-proof port eliminating the need to open the unit and expose it to the elements.

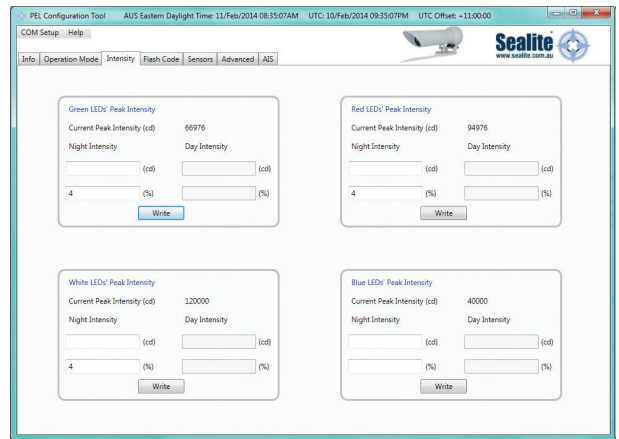

Easily program the PEL with Sealite's PC Configuration Tool

Multiple configurations & maintenance-free

The Port Entry Light can be configured to suit many channel marking and leading line applications. Independently controlled LED drivers provide balanced colour output across colours, or the white centre sector can be increased in intensity to simulate filament/filter combinations.

The Port Entry Light does not require focussing or re-lamping while in service, and there are no moving parts.

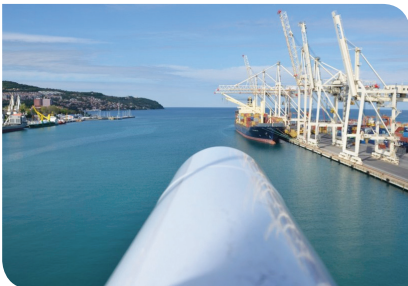

Intensity setting subject to solar availability

Subject to standard terms and conditions

Specifications subject to change or variation without notice
Refer to the Sealite website under the warranty section



Technical Specifications*

	5° Model	10° Model
	SL-PEL-05	SL-PEL-10
Light Characteristics		
Light Source	LED	LED
Available Colours	Red, Green, White	Red, Green, White
Typical Maximum Peak Intensity (cd)	Red - 380,000 Green - 345,000 White - 505,000	Red - 95,000 Green - 85,000 White \leq 120,000
Visible Range (NM)	AT @ 0.74: White sector, nighttime: up to 23.5 AT @ 0.85: White sector, nighttime: up to 37.5 @ 50% peak intensity: 0.85	AT @ 0.74: White sector, nighttime: up to 20 AT @ 0.85: White sector, nighttime: up to 31.3 @ 50% peak intensity: 1.7
Vertical Divergence (degrees)	5	10
Beam Width Overall (degrees)	0.5	1.0
Available Flash Characteristics	User adjustable	User adjustable
Intensity Adjustments	Fully adjustable	Fully adjustable
LED Life Expectancy (hours)	>50,000	>50,000
Electrical Characteristics		
Power (watts)	30 watts peak x character ratio	30 watts peak x character ratio
Voltage Range (VDC)	12-24	12-24
Nominal Voltage (VDC)	12.5	12.5
Temperature Range	-40 to 80°C	-40 to 80°C
Physical Characteristics		
Body Material	Marine grade aluminium alloy & carbon fibre, enamel baking	Marine grade aluminium alloy, subject to enamel baking
Lens Material	Anti-reflection coated glass	Anti-reflection coated glass
Mounting	4 x 12mm slotted holes equally spaced on 200mm PCD with additional front mounting plate consisting of 16mm slotted holes	4 x 12mm slotted holes equally spaced on 200mm PCD
Length (mm/inches)	1272 / 50	756 / 29½
Mass (kg/lbs)	20 / 44	12 / 26½
Product Life Expectancy	Up to 12 years ^	Up to 12 years ^
Environmental Factors		
Driving Rain	MIL-STD-810F Method 506.4	MIL-STD-810F Method 506.4
Low Temperature	MIL-STD-810G Method 502.5	MIL-STD-810G Method 502.5
High Temperature	MIL-STD-810G Method 501.5	MIL-STD-810G Method 501.5
Humidity	MIL-STD-810F Method 507.4	MIL-STD-810F Method 507.4
Salt Fog	MIL-STD-810F Method 509.4	MIL-STD-810F Method 509.4
Shock	IEC 60068-2-29 Test Eb	IEC 60068-2-29 Test Eb
Vibration	ASTM D4169-05 cl.12.3	ASTM D4169-05 cl.12.3
Certifications		
CE	EN61000-6-1: 2007. EN61000-6-3: 2007.	EN61000-6-1: 2007. EN61000-6-3: 2007.
IALA	Signal colours compliant to IALA E-200-1	Signal colours compliant to IALA E-200-1
Waterproof	IP67. AS 60529-2004 (IEC 60529:2001)	IP67. AS 60529-2004 (IEC 60529:2001)
Intellectual Property		
Trademarks	SEALITE® is a registered trademark of Sealite Pty Ltd	SEALITE® is a registered trademark of Sealite Pty Ltd
Warranty *	3 years	3 years
Options Available	<ul style="list-style-type: none"> • AIS Type 1 or Type 3 • GSM Remote Monitoring & Control Capabilities • GPS Synchronisation • Variety of solar/battery configurations 	<ul style="list-style-type: none"> • AIS Type 1 or Type 3 • GSM Remote Monitoring & Control Capabilities • GPS Synchronisation • Variety of solar/battery configurations

^ Refer to the Sealite website under the warranty section

Technical Illustrations

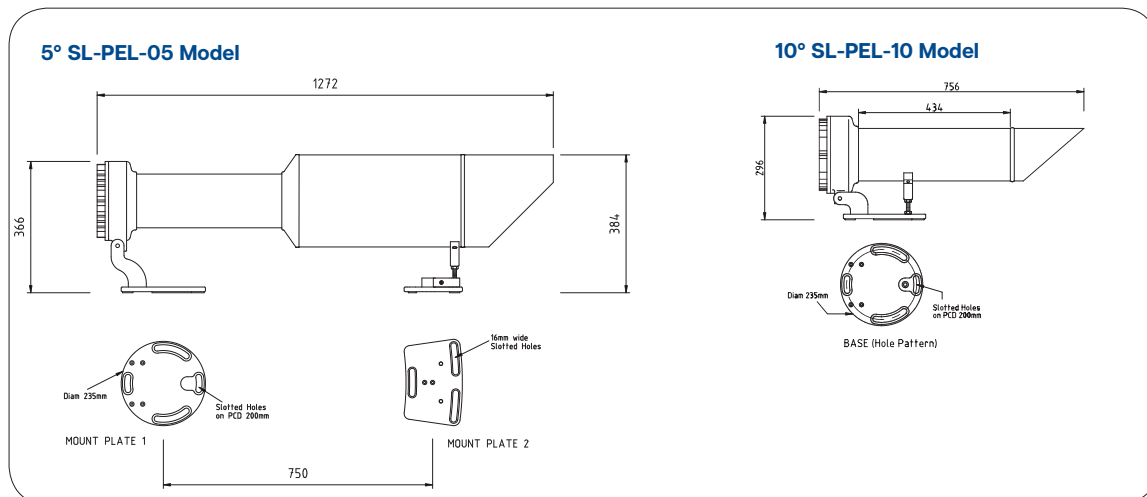

We believe technology improves navigation™

