

WindTalker™ Solar-Powered Ultrasonic Anemometer with GSM

Typical Applications

- Agriculture
- HVAC
- Pollution control
- Portable weather stations
- Roadside weather stations
- Tunnels
- Marine

Major Benefits

- Monitor wind speed & direction using any cell-phone or secure website user-portal login
- Completely self-contained
- Real time information
- GSM network- universal standard for mobile communication
- Corrosion free, UV-stabilised material
- All weather sensing technology
- True 0-359° operation (no dead band)
- Ideal for applications that demand economic wind sensing

Ultrasonic anemometer

Reports wind speed and direction via SMS text message to designated mobile phones and PC's

4 x 10watt multicrystalline solar modules, ensuring maximum light collection to charge the battery

Internal user-replaceable 55Ah battery

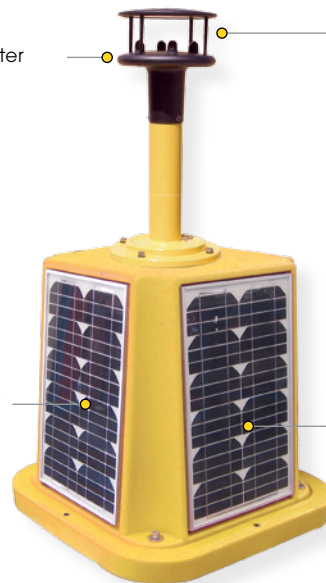

Avlite's WindTalker™ is a solar-powered ultrasonic anemometer which enables users to remotely access real-time and historical data about the wind speed and direction at the location of their installation via cell-phone (SMS message) or PC web portal interface.

The four 10watt multicrystalline solar modules recharge the internal housed battery to power the ultra-sonic anemometer - allowing the unit to be completely self-contained and operate independent from other power sources.

Designated users, such as maintenance personnel, simply send an SMS text message to the wind monitor, and receive an automatic reply from the unit indicating accurate wind speed and direction.

The WindTalker™ has an internally integrated Motorola® cellphone module and Avlite proprietary software to enable data transfer between the unit and designated user's cell-phone (via SMS message) or PC web interface.

In addition various alarm conditions such as high wind speed (user-selectable parameters) and low battery voltage, and daily status reports can also be activated as required.

Avlite's innovative GSM enabled WindTalker™ may also be setup to regularly report wind conditions to a secure user-login portal area of the Avlite website. This provides details of the WindTalker™ wind speed/direction in an easy-to-read PC interface.

Each WindTalker™ is fitted with it's own SIM card, which provides a designated cell-phone contact number for each individual installation. Any network operator can be used providing they have GSM coverage. The ultrasonic anemometer is corrosion-free, and utilises all-weather sensing technology - making the unit ideal for land-based and marine environments.

Typical Applications

- Agriculture
- HVAC
- Pollution control
- Portable weather stations
- Roadside weather stations
- Tunnels
- Marine

WindTalker™

Solar-Powered Ultrasonic Anemometer with GSM

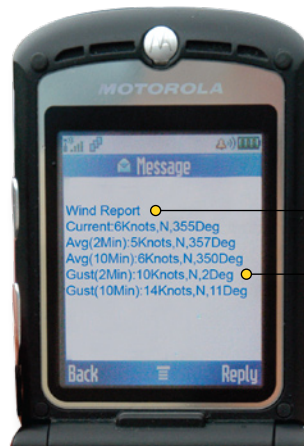
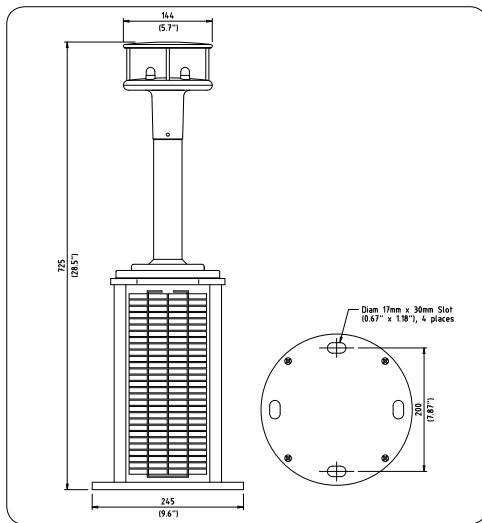

SMS text message with Wind Report

Wind report shows the average wind speed and direction readings over 2 minutes are 5knots North 357 degrees

Average wind gust over 10 minutes is 14knots North 11 degrees

SPECIFICATIONS

Anemometer Characteristics

Wind Speed	Range 0-116 knots
Wind Direction Range	0-359° (no dead band)
Operating Temperature	-35°C to +70°C
Moisture Protection	IP65
External Construction	Polycarbonate
NMEA O/P	Yes
Charging	Internal regulator

Electrical Characteristics

Current Draw (mA)	50mA at 12v (approx)
Circuit Protection	Integrated
Nominal Voltage (v)	12
Autonomy (days)	36
Temperature Range	-40 to 80°C

Solar Characteristics

Solar Module Type	Multicrystalline
Output (watts)	40 (4 x 10watt)
Solar Module Efficiency (%)	14
Charging Regulation	Microprocessor controlled

Power Supply

Battery Type	SLA (Sealed Lead Acid)
Battery Capacity (Ah)	55
Nominal Voltage (v)	12
Battery Service Life	Average 5 years

Physical Characteristics

Body Material	Rotationally moulded UV-stabilised virgin polyethylene
Mounting	4x 11mm mounting holes
Height (mm/inches)	928 / 36 ¹ / ₂
Width (mm/inches)	560 / 22
Mass (kg/lbs)	19 / 41 ¹ / ₄
Product Life Expectancy	Up to 12 years

Certifications

CE	EN61000-6-2:2001. EN61000-6-3:2001
Quality Assurance	ISO9001:2000

Intellectual Property

Trademarks	AVLITE® is a registered trademark of Avlite Systems
Warranty *	1 year

CE

* Specifications subject to change or variation without notice



AVLITE SYSTEMS

11 Industrial Drive
Somerville Victoria 3912 Australia
Ph: +61 (0)3 5977 6128 Fax: +61 (0)3 5977 6124
Web: www.avlite.com Email: info@avlite.com

