

# Accessories

## Typical Applications

- Frangible Plate Mount Kit
- Frangible Stake Mount Kit
- Frangible Coupling
- Mounting Stake
- Top Mounting Plates
- 5kg Non-Slip Tile

## Major Benefits

- 7-stage powder-coated heavy duty aluminum components
- High-visibility yellow colour
- 316-grade stainless steel hardware
- Individual replacement parts available
- Safe, cost effective installation solution

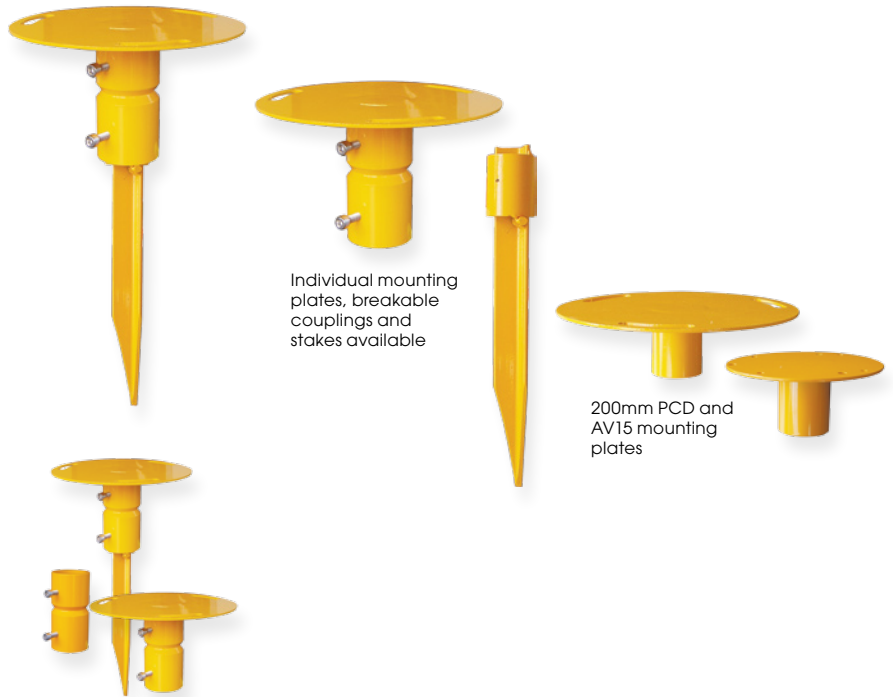

Individual mounting plates, breakable couplings and stakes available

200mm PCD and AV15 mounting plates

Avlite Systems can supply a number of airfield fittings and accessories to complement the range of aviation products including; light base mounting plates, frangible (breakaway) couplings, ground mounting stakes, non-slip tiles and various hardware.

The Avlite stake mount kit includes; light mounting plate, frangible sleeve, ground stake and 316-grade stainless steel hardware. All components (excluding hardware) are made from heavy-duty aluminum, subject to 7-stage powder-coating in high-visibility yellow colour.



The Avlite frangible (breakaway) coupling has been independently tested to comply with FAA Advisory Circular No 150/5345-46B 'Specification for runway and taxiway fixtures'.

# Accessories

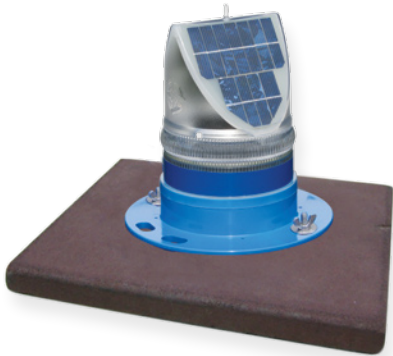
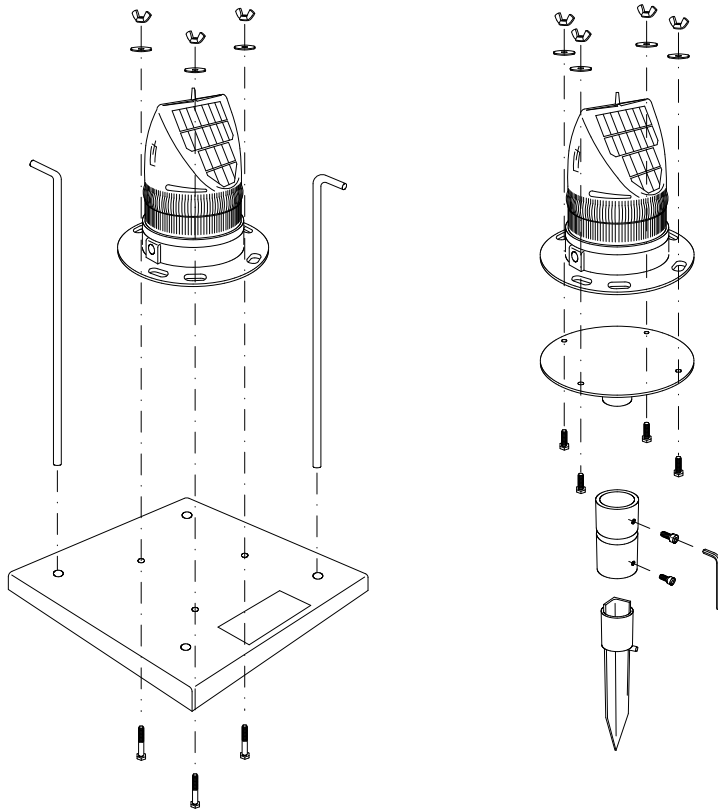

Ease of installation with Avlite Systems 5kg non-slip tile.

**The 5kg non-slip rubber tile allows for fast installation of lights on temporary airfields, and prevents any movement of the lighting fixture.**

Provision exists for mounting the Avlite product to the tile, and a further four mounting holes provide the ability to peg the assembly directly into the ground.



Solar powered temporary airstrip lighting, Loxton Council Airport, South Australia



Fast deployment of AV70 threshold lights on 5kg non-slip tile



## AVLITE SYSTEMS

11 Industrial Drive  
Somerville Victoria 3912 Australia  
Ph: +61 (0)3 5977 6128 Fax: +61 (0)3 5977 6124  
Web: www.avlite.com Email: info@avlite.com

