

SL70

2nm Solar Marine Light

This equipment complies with requirements of the U.S. Coast Guard in 33 CFR part 66



Now available with optional Comm-Synch or Radio Control



Automatic night activation

6 ultra-high intensity LEDs

Lens and base moulded from UV-stabilised LEXAN® polycarbonate

Large industry standard 200mm OD base pattern for ease of installation

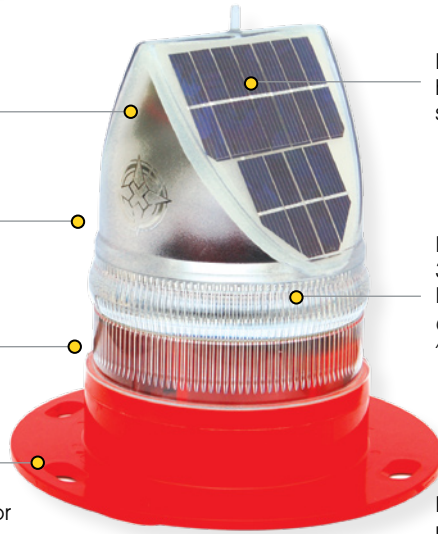

Dual internal high-performance solar modules

LED lens and Sealite's 360° Omnidirectional LED Reflector
(US Pat. No. 6,667,582. AU Pat. No. 778,918)

Internal user-replaceable battery in sealed compartment (IP68 rating)

The Sealite Advantage

- Reliable year-round operation in low sunlight conditions
- 256 IALA flash patterns, user-adjustable without the need for external devices
- User-replaceable battery in sealed battery compartment
- NiMH battery for long service life & wide temperature range
- 4 user-adjustable intensity settings
- ON/OFF storage switch
- IP68 waterproof

The SL70 is exceptional in it's unique ability to be able to 'track the sun' and operate reliably in low sunlight conditions. The SL70 has been proven to operate as a 2-mile compact buoy lantern in various low-sunlight environments such as Britain, Canada, and Europe.

Made from tough, durable polycarbonate and using the latest high intensity LED's, the SL70 lantern boasts dual high-performance solar modules incorporated into Sealite's world-first Solar Collection Lens. These solar modules are angled to obtain maximum sunlight capture, allowing the unit to operate reliably in a range of low sunlight environments.

The SL70 can be installed in minutes, and requires no operator intervention. The flash-characters are easily adjusted on-site by the user, and the lantern has a permanent ON/OFF switch for easy storage.

The sealed battery compartment allows the battery to be replaced after years of service - don't throw the light away at the end of the battery service life.

Sealite's SL70 solar marine light has been awarded the prestigious Australian DesignMark® at the Australian Design Awards; a testament of Sealite's commitment to the ongoing development of state-of-the-art products.

Optional RF Communication Synchronisation (SL70-CS)

The SL70 is now available with optional short-range RF communication synchronisation. Two (2) or more lights can be synchronised to flash in unison via an internal RF module - ideal for rivers, marina entrances, channel marking and aquaculture.

Optional 12 LED Light Configuration (SL70-12)

In high sunlight regions the SL70 may be fitted with 12 LED's and appropriate intensity settings to provide a range of >3 nautical miles (colour dependant).

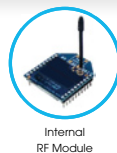

Internal RF Module

RF Comm-Synch SL70 Lanterns



Head Office:
Sealite Pty Ltd
AUSTRALIA

Ph. +61 (0)3 5977 6128
Fax. +61 (0)3 5977 6124
Internet: www.sealite.com.au
Email: info@sealite.com.au

USA Customers:
Sealite USA
USA (Gilford, NH)

Ph. (603) 524-6066
Fax. (603) 524-8100
Internet: www.sealiteusa.com
Email: info@sealiteusa.com

SL70

2nm Solar Marine Light



User replaceable battery

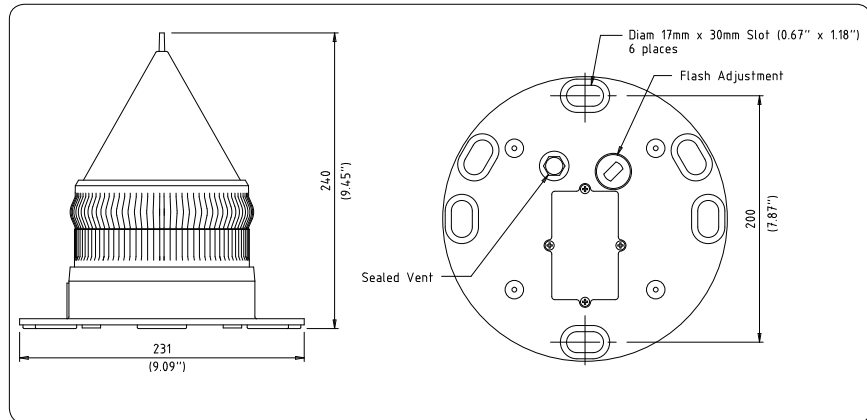

SPECIFICATIONS

Light Characteristics

Light Source	6 ultra-high intensity LEDs
Available Colours	Red, Green, White, Yellow, Blue
Peak Intensity (cd)	Red - 10.0 Green - 10.1 White - 12.1 Yellow - 8.9
Visible Range (nm)	>2
Horizontal Output (degrees)	360
Vertical Divergence (degrees)	9
Reflector Type	Omnidirectional 360° LED Reflector (US Pat. No. 6,667,582. AU Pat. No. 778,918)
Available Flash Characteristics	Up to 256 IALA recommended (user adjustable)
Intensity Adjustments	Adjustable in 25% increments
LED Life Expectancy (hours)	>100,000

Electrical Characteristics

Current Draw (mA)	Minimal
Circuit Protection	Integrated
Nominal Voltage (v)	3.6
Autonomy (days)	30 (14 hour darkness, 12.5% duty cycle)
Temperature Range	-40 to 80°C

Solar Characteristics

Solar Module Type	Multicrystalline
Output (watts)	2.5 (2 x 1.25watt)
Solar Module Efficiency (%)	14
Charging Regulation	Microprocessor controlled

Power Supply

Battery Type	High grade NiMH - Environment friendly
Battery Capacity (Ah)	8
Nominal Voltage (v)	3.6
Battery Service Life	Average 5 years

Physical Characteristics

Body Material	LEXAN® Polycarbonate - UV-stabilised
Lens Material	LEXAN® Polycarbonate - UV-stabilised
Lens Diameter (mm/inches)	150 / 5 ⁷ / ₈
Lens Design	External optics with interior flute design
Mounting	200mm OD base pattern
Height (mm/inches)	240 / 9 ¹ / ₂
Width (mm/inches)	231 / 9 ¹ / ₈
Mass (kg/lbs)	1.1 / 2 ³ / ₈
Product Life Expectancy	Up to 12 years

Certifications

CE	EN61000-6-3:1997. EN61000-6-1:1997
Quality Assurance	ISO9001:2000
Waterproof	IP68

Intellectual Property

Patents	US Pat. No. 6,667,582. AU Pat. No. 778,918
Trademarks	SEALITE® is a registered trademark of Sealite Pty Ltd

Warranty *

Full 3 years

Options Available

- 16Ah battery (SL70/16Ah)
- 12 LEDs (SL70-12)
- Hard-wire synchronisation
- 50mm pole mount adaptor plate
- RF communication synchronisation (SL70-CS)
- Remote radio control (SL70-RC)

CE

• Specifications subject to change or variation without notice

* Subject to standard terms and conditions



Head Office:
Sealite Pty Ltd
AUSTRALIA

Ph. +61 (0)3 5977 6128
Fax. +61 (0)3 5977 6124
Internet: www.sealite.com.au
Email: info@sealite.com.au

USA Customers:
Sealite USA
USA (Gilford, NH)

Ph. (603) 524-6066
Fax. (603) 524-8100
Internet: www.sealiteusa.com
Email: info@sealiteusa.com