

# POSEIDON-1750

## 1750mm dia. Ocean Buoy



Poseidon-1750 Wreck Marking Buoy

316-grade stainless-steel grab rail

Rotationally moulded to 23mm wall thickness

Foam filled with highly buoyant closed-cell polyurethane

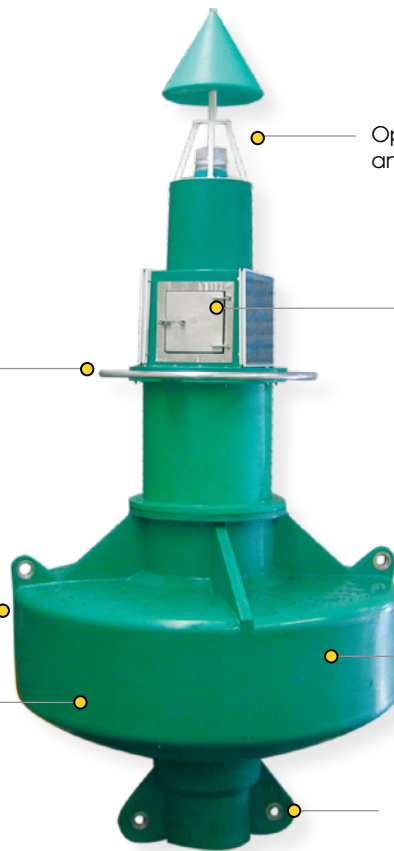

Optional top marks and lights available

316-grade stainless-steel battery access door and compartment

Made from strong, durable UV-stabilised virgin polyethylene

Stainless steel mooring bush

### The Sealite Advantage

- High visibility red, green, white or yellow as per IALA recommendations
- 3 part product; flotation section, mid section & top section
- Individual colouration of each section to suite IALA colour/configuration recommendations
- Excellent buoyancy & stability
- Easy to deploy & service
- No painting, ever
- Cost effective & environmentally friendly

**The Sealite Poseidon-1750 Buoy is manufactured from UV-stabilised virgin polyethylene and has been specifically designed to withstand the harsh marine environment, and operate reliably with minimal maintenance.**

Ports worldwide are realising the advantages of polyethylene buoys over traditional steel models.

The colour pigment is added to the polyethylene during the moulding process, which means that the buoy never requires painting.

The polyethylene material also inhibits marine growth, so the buoy requires cleaning less often than steel types.

Significant advantages of the polyethylene buoy allow the interval between servicing to be far greater, and users continually report major cost savings.

The Poseidon-1750 is constructed from 3 parts ensuring ease of deployment and servicing.



Optional Day Marks

Safe water mark, Australia



**Head Office:**  
Sealite Pty Ltd  
AUSTRALIA

Ph. +61 (0)3 5977 6128  
Fax. +61 (0)3 5977 6124  
Internet: [www.sealite.com.au](http://www.sealite.com.au)  
Email: [info@sealite.com.au](mailto:info@sealite.com.au)

**USA Customers:**  
Sealite USA  
USA (Gilford, NH)

Ph. (603) 524-6066  
Fax. (603) 524-8100  
Internet: [www.sealiteusa.com](http://www.sealiteusa.com)  
Email: [info@sealiteusa.com](mailto:info@sealiteusa.com)

# POSEIDON-1750

## 1750mm dia. Ocean Buoy

The section is internally cross-braced (■) using stainless braces joining each mooring eye to the lifting eye. This ensures mooring and lifting stresses are evenly shared across the structure.

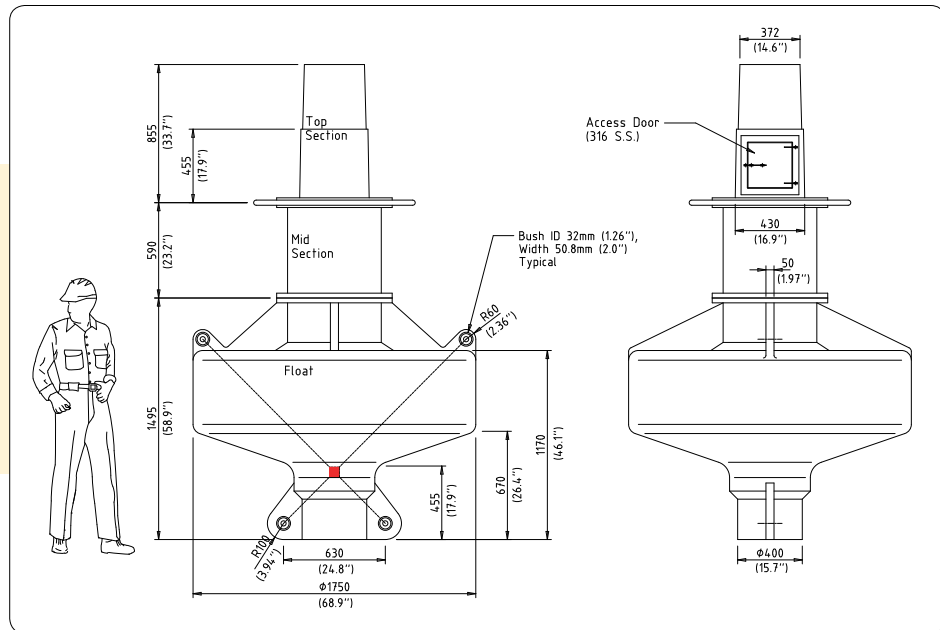

### SPECIFICATIONS •

#### General Characteristics

Available Colours  
Focal Plain Height (mm/inches)  
Total Reserve Buoyancy (kg/lbs)  
Draft, Typical (mm/inches)  
Freeboard (mm/inches)  
Maximum Mooring Load (kg/lbs)

Red, Green, White, Yellow as per IALA Recommendations  
2500 / 98<sup>3</sup>/<sub>8</sub> (standard), 3500 / 137<sup>3</sup>/<sub>4</sub> (with spacer)  
600 / 1323  
680 / 26<sup>3</sup>/<sub>4</sub>  
400 / 15<sup>3</sup>/<sub>4</sub> to 150 / 5<sup>7</sup>/<sub>8</sub>  
600 / 1323

#### Physical Characteristics

Material

Wall Thickness (mm/inches)  
Ballast (kg/lbs)  
Filling  
Height (mm/inches)  
Width (mm/inches)  
Mass (kg/lbs)  
Product Life Expectancy

Rotationally moulded UV-stabilised virgin polyethylene, internal 316-grade stainless-steel bracing, 316-grade stainless-steel fittings, CSIRO slip resistance platform  
23 / 7<sup>7</sup>/<sub>8</sub>  
170 / 375 internal concrete  
Closed-cell polyurethane foam  
2940 / 115<sup>3</sup>/<sub>4</sub>  
1750 / 68<sup>7</sup>/<sub>8</sub>  
505 / 1112  
>20 years

#### Certifications

Quality Assurance

ISO9001:2000

#### Intellectual Property

Trademarks

SEALITE® is a registered trade mark of Sealite Pty Ltd

#### Warranty \*

1 year

#### Lantern Options

Sealite SL60, SL70, SLC310, SLC420 or SL125 series of lantern

#### Accessory Options

- Mould-in graphics
- Day marks
- Sealite IALA recommended top marks
- Monitoring Systems (AIS, GSM cell-phone)
- Radar reflector

CE

• Specifications subject to change or variation without notice

\* Subject to standard terms and conditions

POSEIDON installation, India



Sealite Poseidon Buoy installation, fitted up with an SLC310 light-head, Sint Maarten

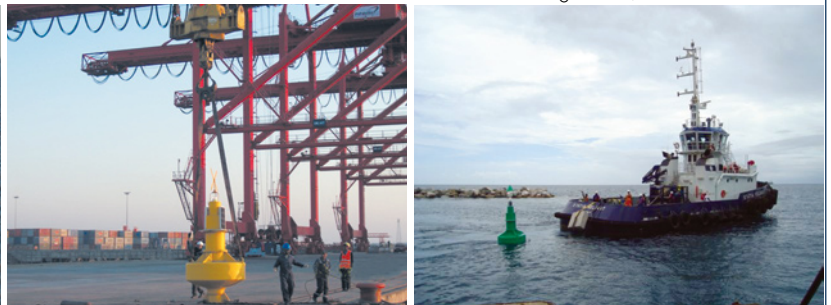

**Head Office:**  
Sealite Pty Ltd  
AUSTRALIA

Ph. +61 (0)3 5977 6128  
Fax. +61 (0)3 5977 6124  
Internet: [www.sealite.com.au](http://www.sealite.com.au)  
Email: [info@sealite.com.au](mailto:info@sealite.com.au)

**USA Customers:**  
Sealite USA  
USA (Gilford, NH)

Ph. (603) 524-6066  
Fax. (603) 524-8100  
Internet: [www.sealiteusa.com](http://www.sealiteusa.com)  
Email: [info@sealiteusa.com](mailto:info@sealiteusa.com)