

AQUAFLOAT-600

600mm dia. Marker Buoy

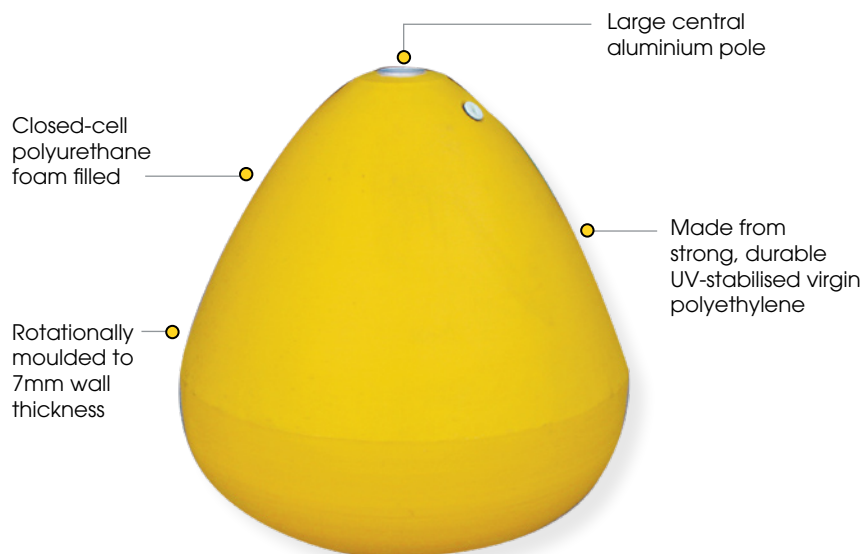

The Sealite Advantage

- High visibility red, green, white or yellow as per IALA recommendations
- Excellent buoyancy

The Sealite Aquafloat-600 is a rotationally moulded marker buoy designed to give customers flexibility in their floating aid requirements.

A large central eye suits a 55mm OD pipe mount, or may be used to aid installation or provide multiple rope anchorage points.

The Aquafloat-600 is urethane foam filled to prevent water ingress in the unlikely event of damage, and is offered in all high-visibility IALA colours.

Aquafloat Special Mark with SL60 light, Manila Ocean Park, Philippines



Photos courtesy of the NSW Department of Fisheries with thanks



Head Office:
Sealite Pty Ltd
AUSTRALIA

Ph. +61 (0)3 5977 6128
Fax. +61 (0)3 5977 6124
Internet: www.sealite.com.au
Email: info@sealite.com.au

USA Customers:
Sealite USA
USA (Gilford, NH)

Ph. (603) 524-6066
Fax. (603) 524-8100
Internet: www.sealiteusa.com
Email: info@sealiteusa.com

AQUAFLOAT-600

600mm dia. Marker Buoy

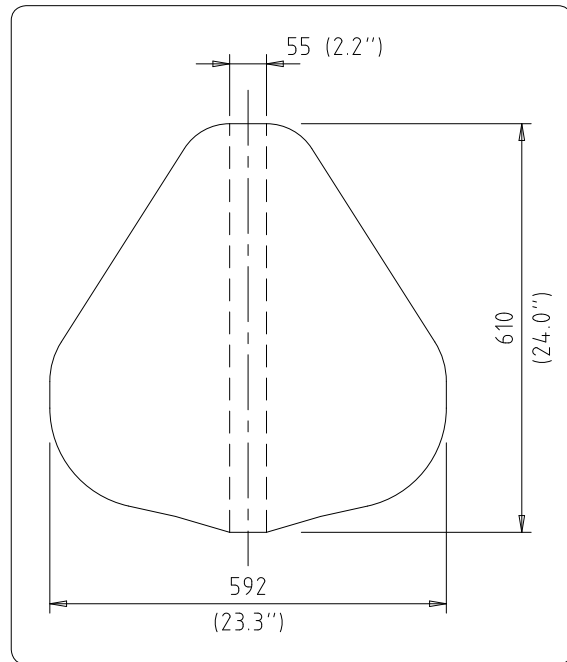

SPECIFICATIONS •

General Characteristics

Available Colours	Red, Green, White, Yellow as per IALA Recommendations
Total Reserve Buoyancy (kg/lbs)	85 / 187
Draft, Typical (mm/inches)	150 / 5 ⁷ / ₈
Maximum Mooring Load (kg/lbs)	35 / 77

Physical Characteristics

Material	Rotationally moulded UV-stabilised virgin polyethylene
Wall Thickness (mm/inches)	7 / 1 ¹ / ₄
Filling	Closed-cell polyurethane foam
Height (mm/inches)	610 / 24
Width (mm/inches)	592 / 23 ¹ / ₃
Mass (kg/lbs)	15 / 33
Product Life Expectancy	Up to 12 years

Certifications

Quality Assurance	ISO9001:2000
-------------------	--------------

Intellectual Property

Trademarks	SEALITE® is a registered trade mark of Sealite Pty Ltd
------------	--

Warranty *

Accessory Options

- 1 year
- Mould-in graphics
- Sealite IALA recommended top marks



- Specifications subject to change or variation without notice
- * Subject to standard terms and conditions

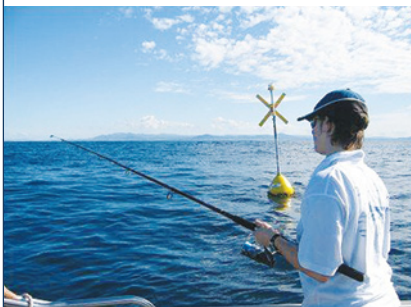

Head Office:
Sealite Pty Ltd
AUSTRALIA

Ph. +61 (0)3 5977 6128
Fax. +61 (0)3 5977 6124
Internet: www.sealite.com.au
Email: info@sealite.com.au

USA Customers:
Sealite USA
USA (Gilford, NH)

Ph. (603) 524-6066
Fax. (603) 524-8100
Internet: www.sealiteusa.com
Email: info@sealiteusa.com