

BargeSafe™ LED Barge Light

**New
Product**

Meets UL 1104
Applicable Sections
for a 3nm Barge Light

Moulded
one-piece handle

Automatic night
activation

Convenient
ON/OFF
switch

Internal
user-replaceable
or rechargeable
battery

1 watt ultra-high
intensity LED

Sealite
world-class
sectored LED
lens to suit UL
1104 certified
configurations

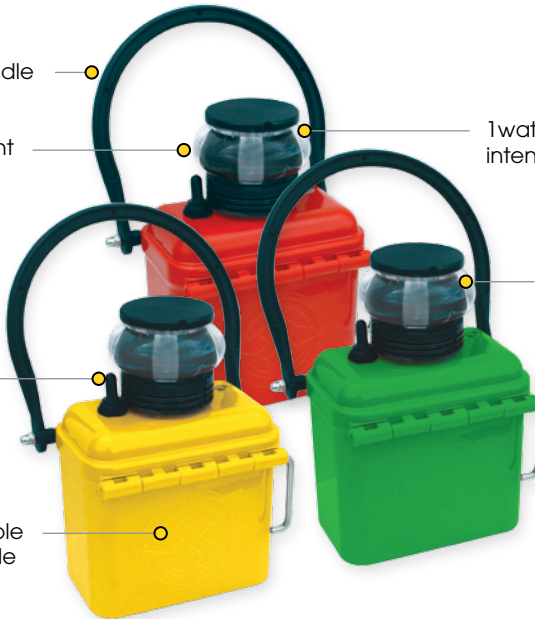

The Sealite Advantage

- UL 1104 certified
- LED technology
- Precise light sectoring achieved via Sealite's world-class in-house designed lens
- 3nm visible range
- Robust
- Installs in seconds
- Low power consumption
- Lightweight

The Sealite BargeSafe™ range of LED barge lights are certified to UL 1104 with >3nm visible range.

The LED barge light is one of the most advanced in its class, and incorporates a host of innovative features designed to make the unit extremely user-friendly.

The world-class LED lens is designed by Sealite and achieves precise intensity and sectoring requirements from a single LED light source. This design helps achieve a lower operational current compared with alternate LED barge lights - making the unit ultra efficient and offering a battery run time of up to 45 nights.

The light will run from a 6v or 12v dry-cell, or can be supplied with an advanced rechargeable battery pack and charge controller. Advanced onboard circuitry incorporates a DC/DC converter which will maintain the required light source intensity over varying battery voltage.

The barge light casing and handle are injected moulded from UV-stabilised polycarbonate - offering enormous impact resistance and long operational life. The casings are coloured for easy identification of light output colour.

A magnetic base provides strong fixing in position to the barge deck.

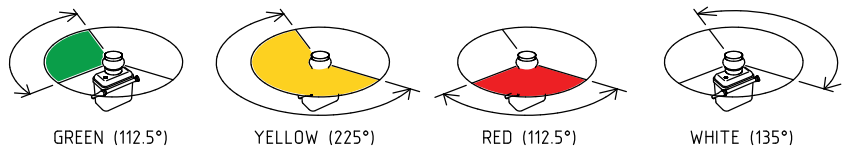

(Yellow required for inland waters)

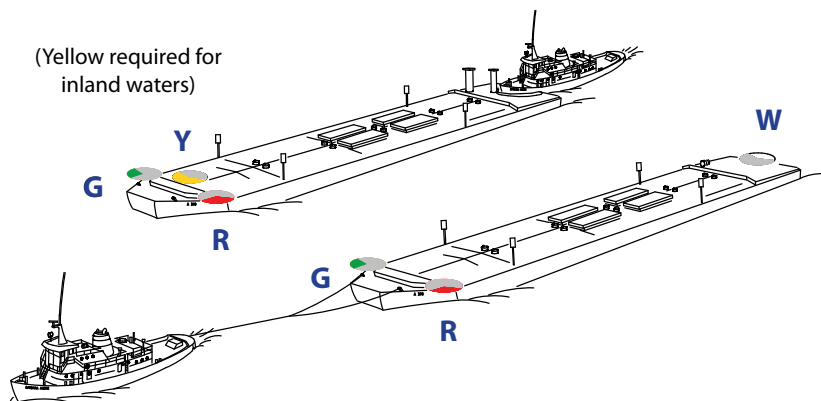

Head Office:
Sealite Pty Ltd
AUSTRALIA

Ph. +61 (0)3 5977 6128
Fax. +61 (0)3 5977 6124
Internet: www.sealite.com.au
Email: info@sealite.com.au

USA Customers:
Sealite USA
USA (Gilford, NH)

Ph. (603) 524-6066
Fax. (603) 524-8100
Internet: www.sealiteusa.com
Email: info@sealiteusa.com

BargeSafe™ LED Barge Light

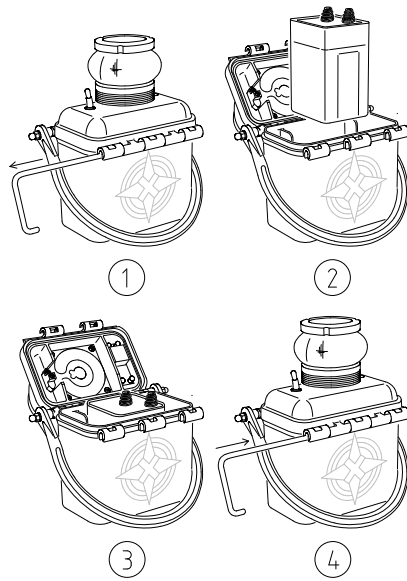

Ease of battery re-charge or replacement

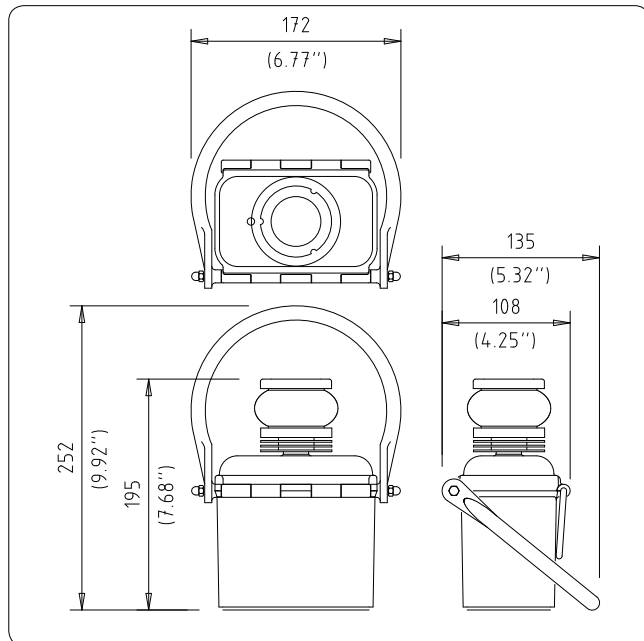

SPECIFICATIONS •

Light Characteristics

Light Source	1x 1 watt ultra-high intensity LED
Available Colours	Red, Green, White, Yellow as per UL 1104
Peak Intensity (cd)	As per UL 1104
Visible Range (nm)	> 3nm as per UL 1104
Horizontal Output (degrees)	Red- 112.5, Green- 112.5, White- 135, Yellow- 225 as per UL 1104
Flash Characteristics	As per UL 1104 (steady-on & flashing)
LED Life Expectancy (hours)	>100,000

Electrical Characteristics

Circuit Protection	Integrated
Working Voltage Range (v)	4 - 16
Temperature Range	-40 to 80°C

Power Supply

Battery Type	Air Alkaline (recommended), rechargeable battery (optional)
Battery Capacity (Ah)	45Ah (Air Alkaline)
Nominal Voltage (v)	6v (Air Alkaline)
Autonomy (days)	>45

Physical Characteristics

Battery Housing	LEXAN® Polycarbonate – UV-stabilised
Lens Material	Acrylic
Lens Mount & Top	Anodized aluminium
Lens Design	Internal single LED cavity with individual sectoring compartments to meet all UL 1104 angles for light output
Mounting	4x magnets
Height (mm/inches)	195 / 7 ² / ₃
Width (mm/inches)	172 / 6 ⁷ / ₈
Depth (mm/inches)	108 / 4 ¹ / ₄
Mass (kg/lbs)	1.5 / 3 ¹ / ₃
Product Life Expectancy	Up to 12 years

Certifications

Approvals	UL 1104
Quality Assurance	ISO9001:2000
Waterproof	IP67

Intellectual Property

Trademarks	BargeSafe™ is a trademark of Sealite Pty Ltd
------------	--

Warranty *

1 year



• Specifications subject to change or variation without notice * Subject to standard terms and conditions



Head Office:
Sealite Pty Ltd
AUSTRALIA

Ph. +61 (0)3 5977 6128
Fax. +61 (0)3 5977 6124
Internet: www.sealite.com.au
Email: info@sealite.com.au

USA Customers:
Sealite USA
USA (Gilford, NH)

Ph. (603) 524-6066
Fax. (603) 524-8100
Internet: www.sealiteusa.com
Email: info@sealiteusa.com