

1750mm dia. Ocean Buoy

POSEIDON-1750

Sealite have a range of mooring chains & accessories - ask your representative today how we can supply your complete mooring solution



Environmentally Friendly & Recyclable

Sealite buoy products are made from recyclable materials. As a service to customers, individual components and products at the end of their service life may be returned to Sealite for recycling.



POSEIDON-1750 Wreck Marking Buoy

The Sealite POSEIDON-1750 Buoy is manufactured from UV-stabilised, virgin polyethylene and has been specifically designed to withstand the harsh marine environment, and operate reliably with minimal maintenance.

Ports worldwide are realising the advantages of polyethylene buoys over traditional steel models.

The colour pigment is added to the polyethylene during the moulding process, which means that the buoy never requires painting.

The polyethylene material also inhibits marine growth, so the buoy requires cleaning less often than steel types.

Significant advantages of the polyethylene buoy allow the interval between servicing to be far greater and users continually report major cost savings.

The POSEIDON-1750 is constructed from 3 parts ensuring ease of deployment and servicing. The float section incorporates two large lifting and mooring points, interconnected by 316-grade stainless steel tie-bars to provide greater strength. The mid-section may be supplied with a large secondary battery enclosure, whilst the top section is designed to carry the buoy's primary payload.

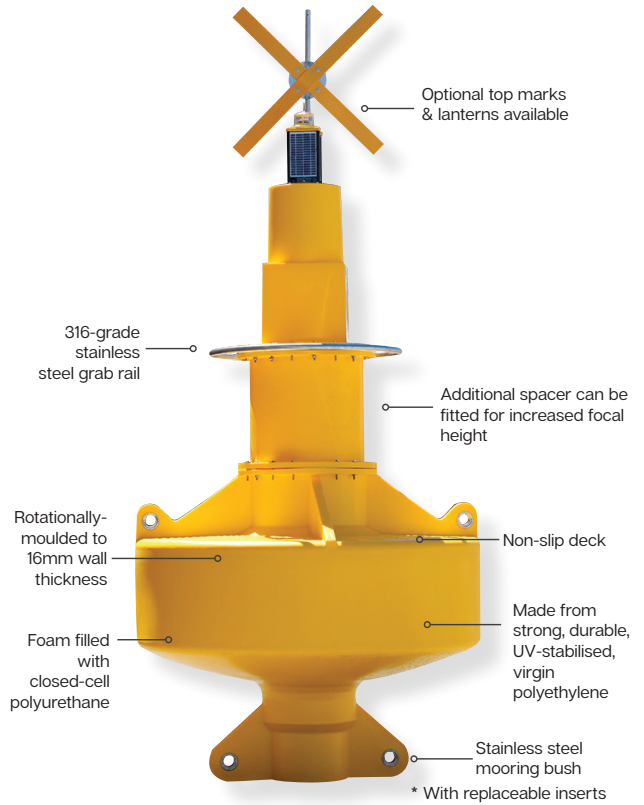

The Sealite Advantage

- High visibility red, green, white or yellow as per IALA recommendations
- Individual colouration of each section to suit IALA colour/configuration recommendations
- Excellent buoyancy & stability
- Easy to deploy & service
- No painting, ever
- Cost effective & environmentally friendly
- Replaceable mooring bush inserts *

Technical Illustrations

The float section is internally cross-braced (■) using stainless steel braces joining each mooring eye to the lifting eye. This ensures mooring and lifting stresses are evenly shared across the structure.

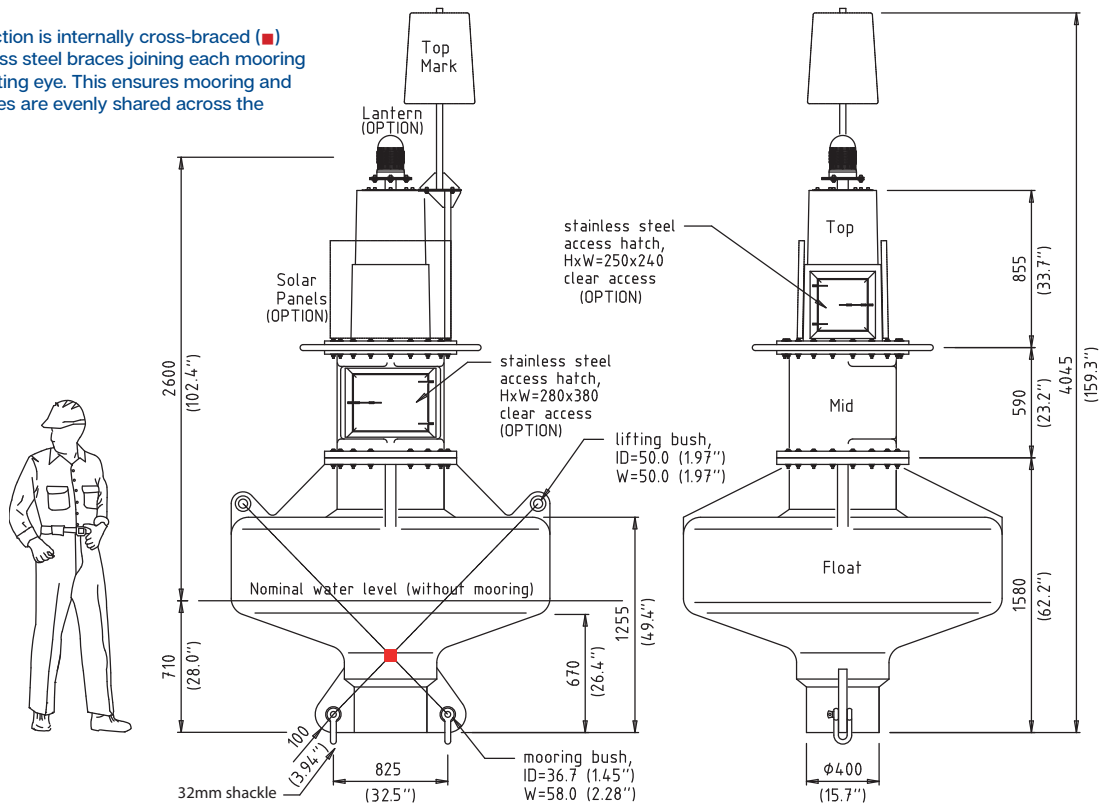

Technical Specifications.*

POSEIDON-1750

General Characteristics

Available Colours	Red, Green, White, Yellow as per IALA Recommendations
Focal Plane Height (mm/inches)	2600 / 101.8 (standard). 3090 / 121½ (with spacer)
Total Float Volume (ltrs/US gallon)	1815 / 480
Nominal Freeboard (mm/inches)	545 / 21.5
Nominal Draft (mm/inches)	710 / 28
Total Reserve Buoyancy (kgs/lbs)	1387 / 3058
Operational Buoyancy (kgs/lbs)	600 / 1323
Maximum Mooring Load (kgs/lbs)	600 / 1323
Draft, Maximum (mm/inches)	955 / 37.6
Freeboard, Minimum (mm/inches)	300 / 11.8
Safe Working Load, 1pt (kgs/lbs)	2300 / 5070
Safe Working Load, 2pt (kgs/lbs)	3250 / 7165
Submergence (kg/cm, lb/inches)	24.5 / 137
Visual Area (m ² /ft ²)	1.9 / 20.4

Physical Characteristics

Material	Rotationally-moulded UV-stabilised virgin polyethylene, internal 316-grade stainless steel bracing, 316-grade stainless steel fittings, slip resistant platform
Wall Thickness (mm/inches)	16 / ¾ (float section)
Ballast (kg/lbs)	150 / 330 internal concrete
Filling	Closed-cell polyurethane foam (float section)
Height (mm/inches)	4045 / 159
Width (mm/inches)	1750 / 68¾
Mass (kg/lbs)	428 / 944
Radar Reflector	Echomax 230 Midi (RSC 10m ² per RORC/ORC)
Product Life Expectancy	>20 years ^

Certifications

IALA	Surface colours compliant to IALA E-108
Quality Assurance	ISO9001: 2015

Intellectual Property

Trademarks SEALITE® is a registered trademark of Sealite Pty Ltd

Warranty *

5 years

Lantern Options

Options Available

- Sealite SL-75, SL-C310, SL-C410, SL-C415, SL-C420, SL-125 Series or SL-155 Series
- Custom signage
 - Monitoring Systems (AIS, GSM)
 - Solar power supplies

* Specifications subject to change or variation without notice
 ^ Refer to the Sealite website under the warranty section
 • Subject to standard terms and conditions



We believe technology improves navigation™



Sealite Pty Ltd
Australia
☎ +61 (0)3 5977 6128

Sealite Asia Pte Ltd
Singapore
☎ +65 6908 2917

Sealite United Kingdom Ltd
UK
☎ +44 (0) 1502 588026

Sealite USA LLC
USA
☎ +1 (603) 737 1311

