

2ft Leading Light

SL-48

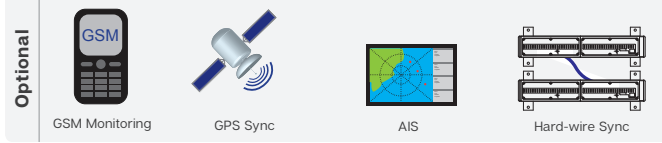

The SL-48 is a 2ft LED leading light designed to offer vessels clear night navigation and is a convenient replacement for conventional lead lighting.

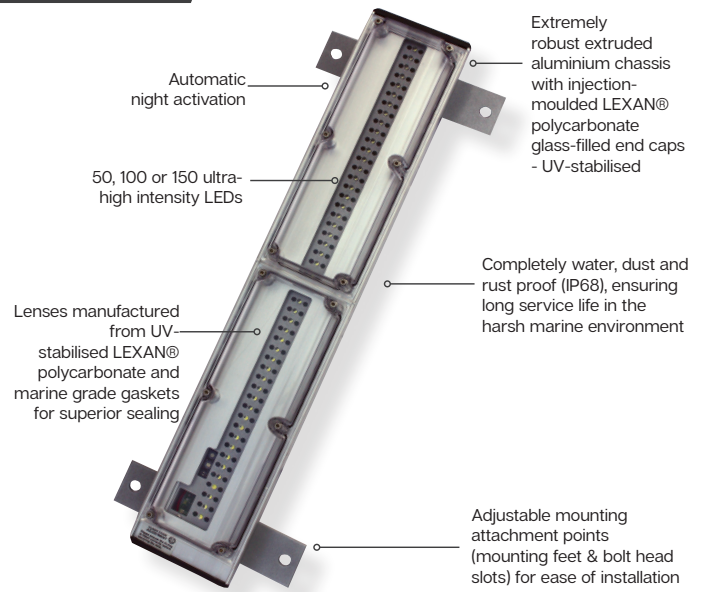

The unit is available in 3 configurations utilising either single, dual, or triple row LED circuits as a light source.

The advanced circuitry of the SL-48 series comprise of a DC/DC converter, current control and automatic night activation.

The innovative, robust design of the SL-48 leading light ensures years of reliable, maintenance-free service. The unit is completely water, dust & rust proof, and vandal resistant.

The SL-48 body is made from extruded aluminium with injection-moulded UV-stabilised LEXAN® polycarbonate glass-filled end caps for superior strength and durability. Single, dual and triple row versions have the same body width.

Individual injection-moulded LEXAN® polycarbonate lenses are fitted to the aluminium body with a marine grade gasket ensuring a superior sealing (IP68 waterproof).

The aluminium housing features 2x channels/slots which run along the entire length of the base of the SL-48. This multi-mount design allows the 2x mounting brackets/feet to be positioned as required for complete installation flexibility.

The unit operates from a standard 8 – 20 volt power supply, and may be run from a mains powered system or with solar and battery backup in the event of power failure.

The SL-48 Leading Light is also available with hard-wire or GPS Synchronisation and GSM Remote Monitoring and Control capabilities. When leading lights flash in synchronisation, they can be clearly distinguished from other nav aids and confusing background lighting.

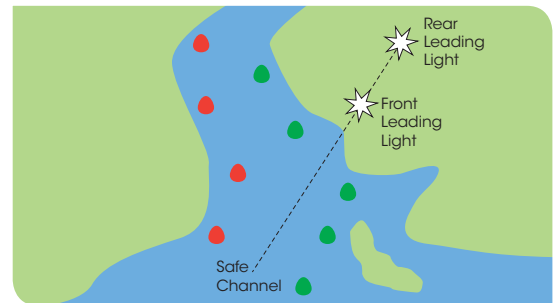

User Advantage

- Directional 2ft LED leading light
- 7.5 - 13+ nautical mile range
- Robust design ensures a complete seal suitable for extreme weather conditions
- 256 user-adjustable flash characteristic
- Adjustable intensity settings
- Operates in conjunction with existing or purpose-built power supplies

Optional

- Optional GPS Synchronisation & GSM Remote Monitoring
- Optional solar powered configurations available

Reliable

- IP68 waterproof

Technical Specifications *

	SL-48-1	SL-48-2	SL-48-3
	Single Row	Dual Row	Triple Row
Light Characteristics			
Light Source	50 ultra-high intensity LEDs	100 ultra-high intensity LEDs	150 ultra-high intensity LEDs
Available Colours	Red, Green, White, Yellow, Blue	Red, Green, White, Yellow, Blue	Red, Green, White, Yellow, Blue
Typical Maximum Intensity (cd)*	Red - 1540 Green - 2220 White - 2220 Yellow - 1320 Blue - 430	Red - 3070 Green - 4160 White - 4020 Yellow - 2570 Blue - 770	Red - 4560 Green - 6300 White - 5680 Yellow - 3820 Blue - 1140
Visible Range (NM)	8	9	10
Horizontal Output (degrees)	15	15	15
Vertical Divergence (degrees)	15	15	15
Available Flash Characteristics	Up to 256 IALA recommended (user adjustable)	Up to 256 IALA recommended (user adjustable)	Up to 256 IALA recommended (user adjustable)
Intensity Adjustments	User adjustable	User adjustable	User adjustable
LED Life Expectancy (hours)	>100,000	>100,000	>100,000
Electrical Characteristics			
Current Draw (mA)	Red, Yellow - 510 Blue, Green, White - 430	Red, Yellow - 1020 Blue, Green, White - 860	Red, Yellow - 1530 Blue, Green, White - 1290
Circuit Protection	Polarity protected	Polarity protected	Polarity protected
Nominal Voltage (V)	12	12	12
Temperature Range	-40 to 80°C	-40 to 80°C	-40 to 80°C
Physical Characteristics			
Body Material	Extruded aluminium chassis with LEXAN® polycarbonate glass-filled end caps - UV-stabilised	Extruded aluminium chassis with LEXAN® polycarbonate glass-filled end caps - UV-stabilised	Extruded aluminium chassis with LEXAN® polycarbonate glass-filled end caps - UV-stabilised
Lens Material	LEXAN® Polycarbonate - UV-stabilised	LEXAN® Polycarbonate - UV-stabilised	LEXAN® Polycarbonate - UV-stabilised
Mounting	Slots to suit head of M6 Hex bolt (full length of light body) & 4 x 11.5mm mounting holes (mounting feet)	Slots to suit head of M6 Hex bolt (full length of light body) & 4 x 11.5mm mounting holes (mounting feet)	Slots to suit head of M6 Hex bolt (full length of light body) & 4 x 11.5mm mounting holes (mounting feet)
Height (mm/inches)	86 / 3 $\frac{3}{8}$	86 / 3 $\frac{3}{8}$	86 / 3 $\frac{3}{8}$
Width (mm/inches)	200 / 7 $\frac{7}{8}$ (including feet)	200 / 7 $\frac{7}{8}$ (including feet)	200 / 7 $\frac{7}{8}$ (including feet)
Length (mm/inches)	650 / 25 $\frac{3}{4}$	650 / 25 $\frac{3}{4}$	650 / 25 $\frac{3}{4}$
Mass (kg/lbs)	3.6 / 7 $\frac{7}{8}$	3.7 / 8 $\frac{1}{8}$	3.8 / 8 $\frac{1}{8}$
Product Life Expectancy	Up to 12 years ^	Up to 12 years ^	Up to 12 years ^
Certifications			
CE	EN61000-6-3:1997. EN61000-6-1:1997	EN61000-6-3:1997. EN61000-6-1:1997	EN61000-6-3:1997. EN61000-6-1:1997
IALA	Signal colours compliant to IALA E-200-1	Signal colours compliant to IALA E-200-1	Signal colours compliant to IALA E-200-1
Quality Assurance	ISO 9001:2015	ISO 9001:2015	ISO 9001:2015
Waterproof	IP68	IP68	IP68
Intellectual Property			
Trademarks	SEALITE® is a registered trademark of Sealite Pty Ltd	SEALITE® is a registered trademark of Sealite Pty Ltd	SEALITE® is a registered trademark of Sealite Pty Ltd
Warranty * Options Available	3 years <ul style="list-style-type: none"> Power supplies/systems Hard-wire Synchronisation GPS Synchronisation GSM Remote Monitoring & Control Capabilities AIS Remote Monitoring Additional cable 	3 years <ul style="list-style-type: none"> Power supplies/systems Hard-wire Synchronisation GPS Synchronisation GSM Remote Monitoring & Control Capabilities AIS Remote Monitoring Additional cable 	3 years <ul style="list-style-type: none"> Power supplies/systems Hard-wire Synchronisation GPS Synchronisation GSM Remote Monitoring & Control Capabilities AIS Remote Monitoring Additional cable

* Subject to standard terms and conditions + Intensity setting subject to solar availability

• Specifications subject to change or variation without notice
^ Refer to the Sealite website under the warranty section



Ease of flash setting selection (where required) via internal rotary switches

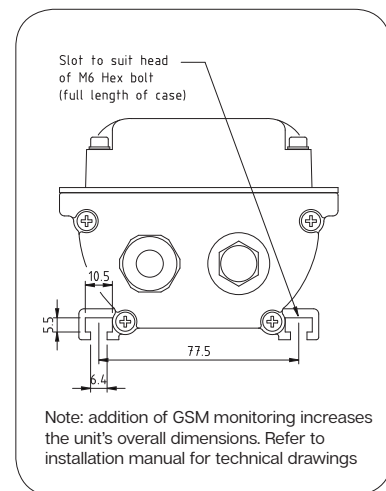

We believe technology improves navigation™



Sealite Pty Ltd
Australia
+61 (0)3 5977 6128

Sealite Asia Pte Ltd
Singapore
+65 6829 2243

Sealite United Kingdom Ltd
UK
+44 (0) 1502 588026

Sealite USA LLC
USA
+1 (603) 737 1311

